

FS CS090SL.WPC

WorkPiece Carrier curve conveyor system

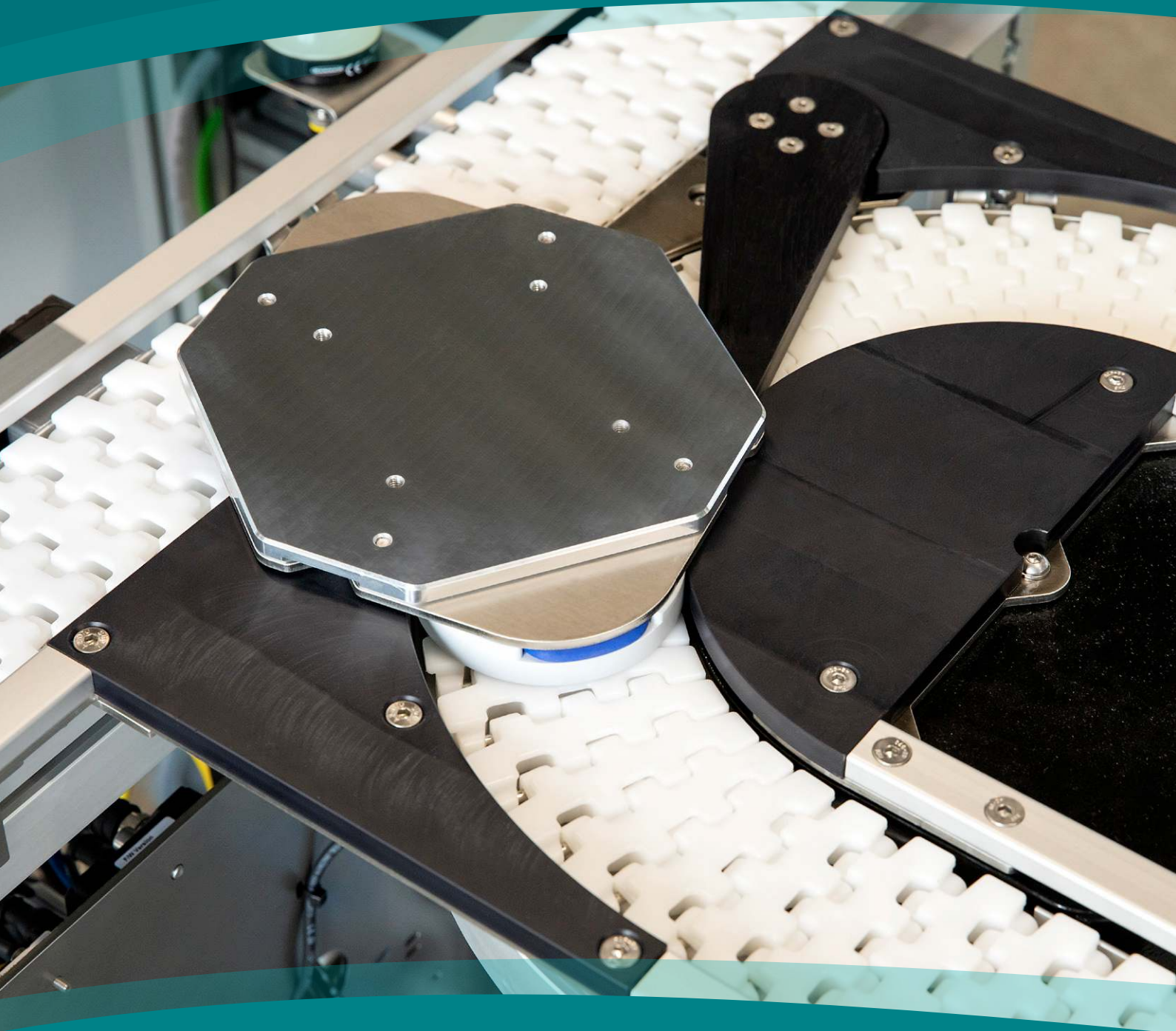



FS Solutions BV
Klavermaten 63
7472 DD Goor

T +31 548 515 115
E info@fssolutions.nl
W www.fssolutions.eu

INDEX WORKPIECE CARRIER CURVE CONVEYOR SYSTEM

FS CS090SL.WPC

WorkPiece Carrier curve conveyor system



WORKPIECE CARRIER CURVE CONVEYOR SYSTEM

The perfect WorkPiece Carrier curve conveyor system for automated handling of products

The FS-CS090SL.WPC workpiece carrier system is the answer to conveying workpiece carriers holding products from numerous sectors, such as the automotive industry or the electrical and electronics industry. FS-CS090SL.WPC is particularly suitable for interlinking machines and manual workstations as well as for feeding parts in automated production and assembly processes.

Based on the familiar and proven modular chain conveyor system: FS CS090SL, additional components are used for constructing the WorkPiece Carrier system. In addition to the FS CS090SL.ALU components, such as conveyor profile, conveyor chain, drives, horizontal curves with disc and legs, the system is complemented with the use of:

- Workpiece carriers
- Railing components
- Lift-out/ positioning unit
- Stoppers
- Sensors
- Dividing sections
- Identification system (RFID)

“With over 10 years of experience and know-how, FS Solutions is guaranteed to find you a high-end solution.”

The contents of this publication are the copyright of the publishers and may not be reproduced (even extracts) unless permission is granted. Every care has been taken to ensure the accuracy of the information but no liability can be accepted for any errors or omissions. The right is reserved to make design modifications.

PATENTS

Parts of the FS Solutions product range are protected by patents and design regulations. Drawings are made to European standards.

© FS Solutions 2023

ICON OVERVIEW

GENERAL



Note Caution



Weight



Fabrication



Packaging unit



Tools



Mounting



Material



Cutting profile to length



Energy Efficiency



Colour



Left-hand version LS/
right-hand version RS



Surface



Type/Version

SYSTEM RELATED



Chain Type



Drive motor



Effective chain length



Maximum permissible
chain pulling force



Conveyor chain material



Effective chain length -
inside curve



Maximum conveying speed



Profile series



Effective chain length -
outside curve



Maximum permissible
line length

DIMENSIONS



Sizes, dimensions



Thread

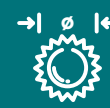

Drive pitch diameter



Width



Idler radius



Angle



Length



Idler angle

FS CS090SL.WPC LINE ROUTING



Identifying, stopping, distributing or buffering

Various modules for identifying, stopping, distributing or buffering workpiece carriers can be used for creating sophisticated line routing layouts in a very short time. Standardized divider modules provide the capability of channeling workpiece carrier flows onto main and branch lines. The optional use of RFID chips in the workpiece carrier makes it possible to identify and track conveying movements throughout the production line.

Example of a production line

The process of conveying workpiece carriers takes place on the main line (see figure). Divider modules are used for diverting workpiece carriers onto branch lines. This is where various processing activities can take place or where parts can be put together to produce assemblies.

On completion of processing, the workpiece carriers are channeled back onto the main line. The combination of a main line with one or several branch lines is also referred to as a cell. Cells can also be interconnected in the same way as main and branch lines.

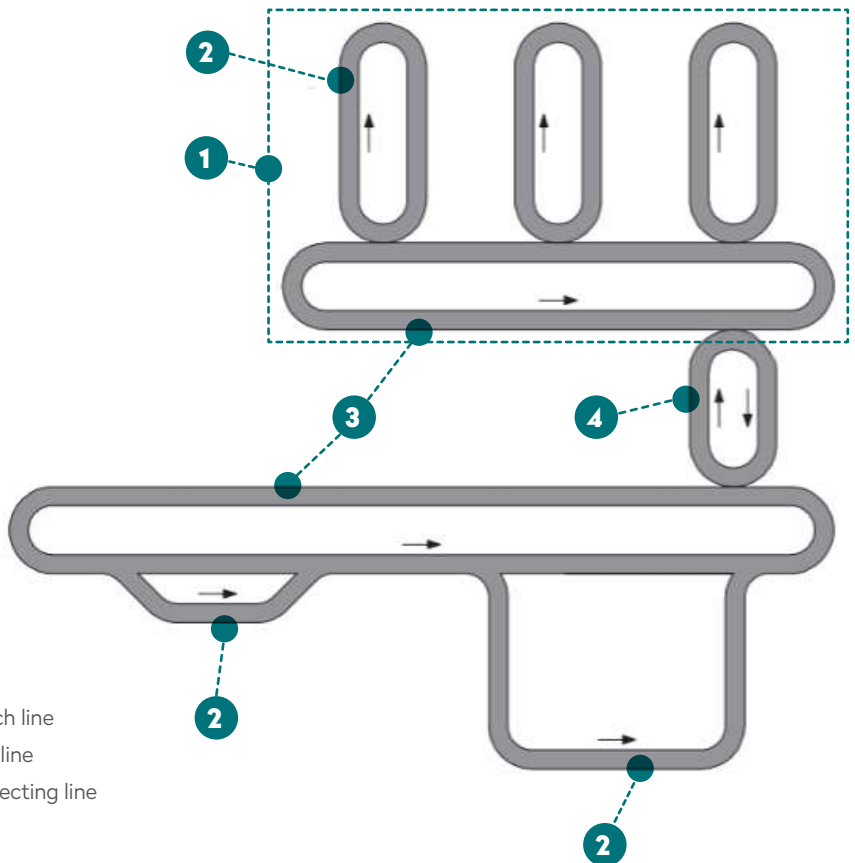



FS CS090SL.WPC LINE ROUTING

WORKPIECE CARRIER CURVE CONVEYOR SYSTEM

FS CS090SL.WPC SYSTEM INFORMATION

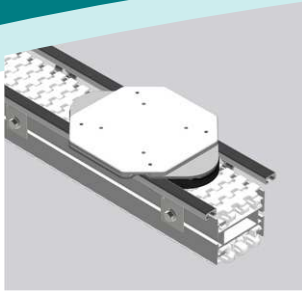

Interlinking machines and manual workplaces as well as feeding parts in automated production and assembly processes.

CONVEYOR LINE

- Maximum load 150 kg
- Max. conveying length 20 m
- Max. conveying speed 30 m/min
- Available drives:
 - Vertical drive
 - Direct drive
 - Combination drive
- Railing system for workpiece carriers

WORKPIECE CARRIER (WPC)

- Usable width 150 mm
- Loading capacity - Product data:
 - Max. product weight 10 kg

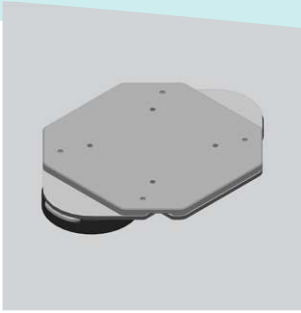

FS CS090SL.WPC WORKPIECE CARRIER

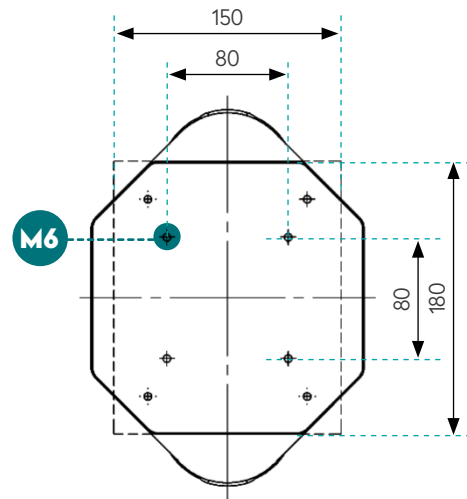

| WORKPIECE CARRIER

- Flat surface workpiece carrier.
- Sturdy design.
- Integrated centering bushes for lift-up / positioning unit.
- Suitable for accumulating conveyor mode.
 - by means of sliding plates in low friction plastic
 - optional: Sliding plates with damper on one side.
- Loading capacity – Product data:
 - Usable width 150 mm
 - Max. product weight 10 kg



	PROD.NO.		
Workpiece carrier (without damper)	886001-001	1	Aluminium
Workpiece carrier (with damper)	886001-002	1	Aluminium

FS CS090S.WPC DIVIDER

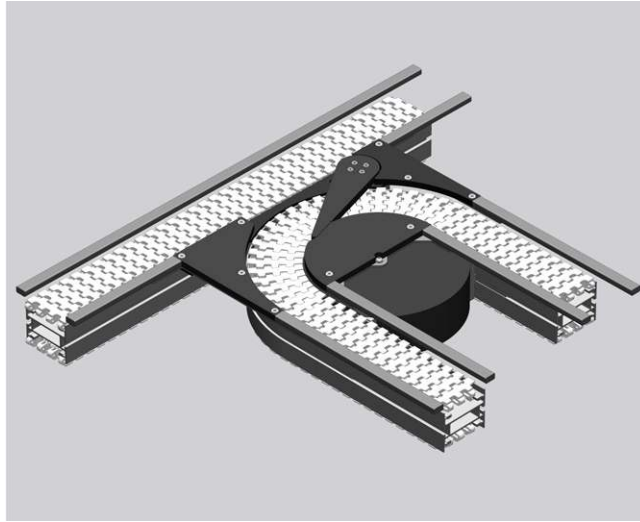
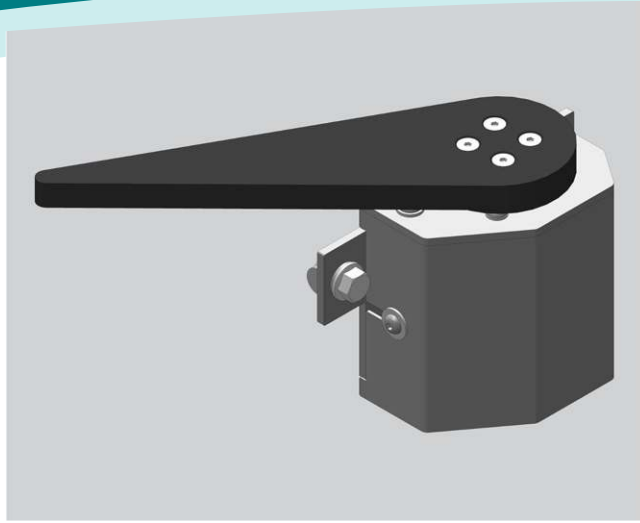

FS CS090S.WPC DIVIDER

WORKPIECE CARRIER CURVE CONVEYOR SYSTEM

FS CS090SL.WPC DIVIDER

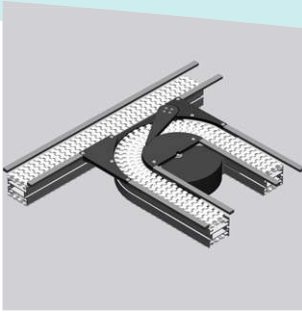

| DIVIDER

- Dividers for changing between line sections.
- The line crossover bridges the gap, allowing workpiece carriers to cross over without tipping.
- All-inclusive kit for fitting to existing lines, consisting of:
 - Divider with pneumatically actuated switch blade
 - Parallel line section joint Line crossover
 - Railing accessories
 - Fixing material. No accumulation permissible onto switch blade!
- No accumulation permissible onto the switch blade!

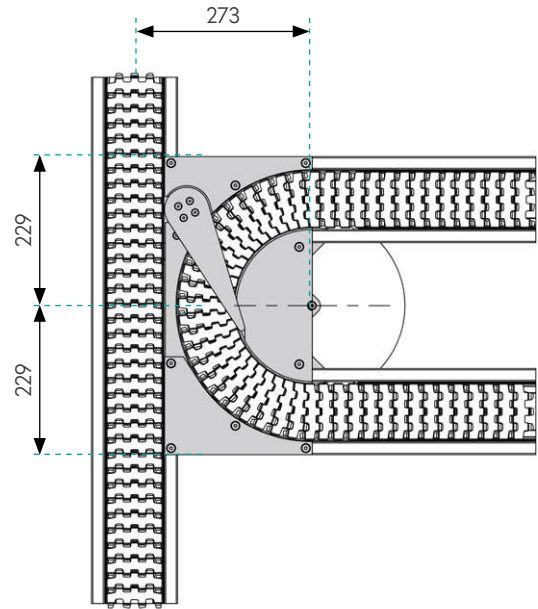

			PROD.NO.		
Divider kit, incl fixing material	A	RS	886007-301	45	1
Divider kit, incl fixing material	B	LS	886007-302	45	1
Divider kit, incl fixing material	C	RS	886007-303	90	1
Divider kit, incl fixing material	D	LS	886007-304	90	1
Divider kit, incl fixing material	E	RS	886007-305	135	1
Divider kit, incl fixing material	F	LS	886007-306	135	1
Divider kit, incl fixing material	G	RS	886007-307	180	1
Divider kit, incl fixing material	H	LS	886007-308	180	1
Divider kit, incl fixing material	I	RS 2	886007-321	90	1
Divider kit, incl fixing material	J	LS 2	886007-322	90	1
Divider kit, incl fixing material	K	RS 2	886007-323	135	1
Divider kit, incl fixing material	L	LS 2	886007-324	135	1
Divider kit, incl fixing material	M	RS 1	886007-325	180	1
Divider kit, incl fixing material	N	LS 1	886007-326	180	1
Divider kit, incl fixing material	O	RS 3	886007-327	135	1
Divider kit, incl fixing material	P	LS 3	886007-328	135	1
Divider kit, incl fixing material	Q	RS 3	886007-329	180	1
Divider kit, incl fixing material	R	LS 3	886007-330	180	1
Divider kit, incl fixing material	S	RS 4	886007-331	180	1
Divider kit, incl fixing material	T	LS 4	886007-332	180	1
Stand-alone divider, incl fixing material	U	RS	886007-001		1
Stand-alone divider, incl fixing material	V	LS	886007-002		1

FS CS090S.WPC DIVIDER

FS CS090SL LINE COMPONENTS

WORKPIECE CARRIER CURVE CONVEYOR SYSTEM

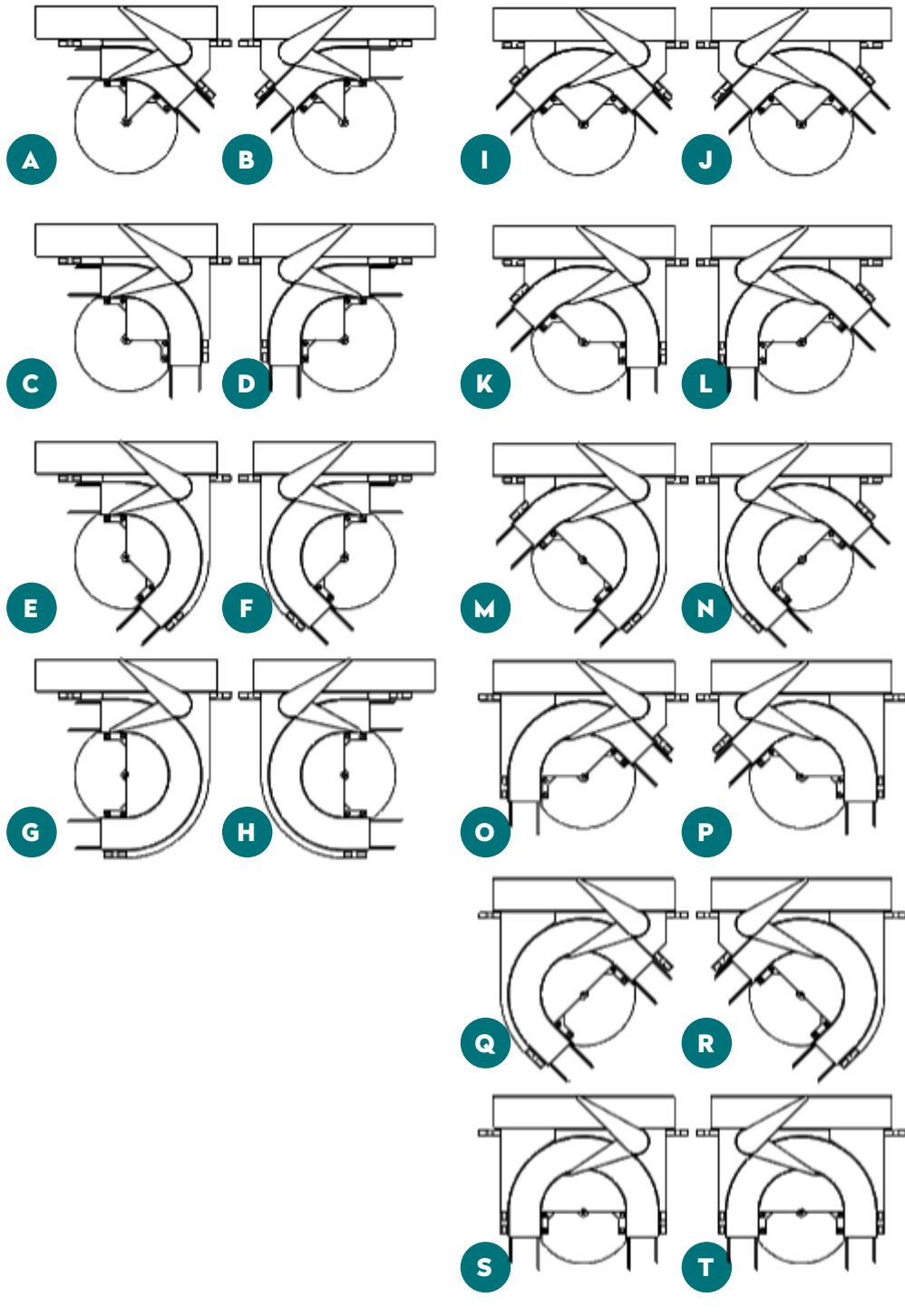

FS CS090SL.WPC INDEXING STATION

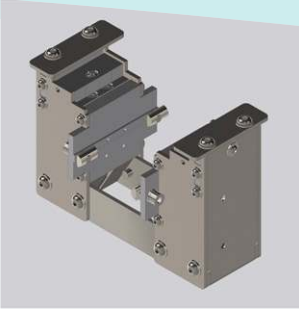

- Lifting unit for workpiece carriers
- Lifting with accurate centering bushes
- Repeat accuracy is +/- 0,1mm
- Can be retrofitted at any position along the conveyor line without interrupting the railing.
- Holder and fixing material included.
- Please order stopper separately.

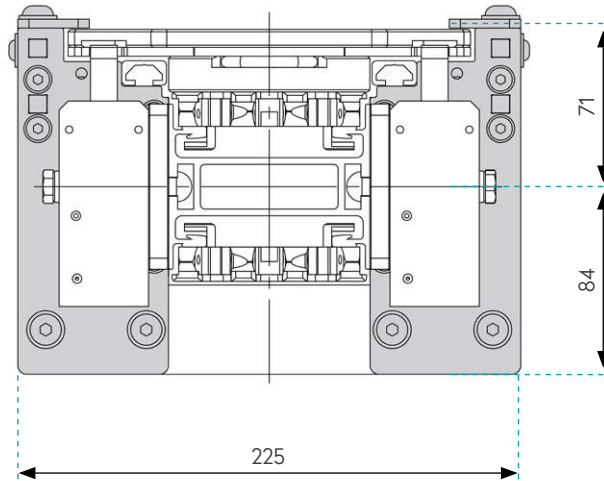
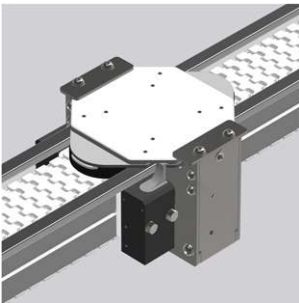

	PROD.NO.	
FS-CS090SL.WPC Indexing station, including fixing material	886008-001	1

FS CS090SL.WPC IDENTIFICATION STATION M18



- Sensor for identifying specific workpiece carriers, consisting of:
 - ID system (read unit): Turck TN-M18-IOL2-H1141 RFID Read & write head
 - Can be retrofitted at any position along the conveyor line without interrupting the railing.
 - Please order Mobile data carrier (RFID chip) separately.
 - Holder and fixing material included.

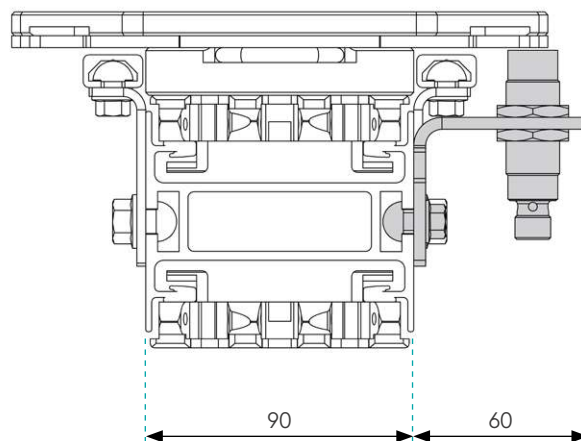
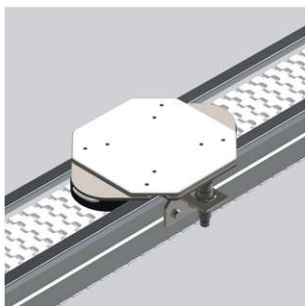

FS CS090SL.WPC IDENTIFICATION STATION M18

WORKPIECE CARRIER CURVE CONVEYOR SYSTEM

	PROD.NO.	
FS-CS090SL.WPC Identification station M18, including fixing material, sensor included	886009-002	1
FS-CS090SL.WPC Individual M18 sensor bracket, without sensor, including fixing material	886009-011	1

FS CS090SL.WPC POSITION SENSOR STATION



- Sensor for detecting the position of workpiece carriers.
- Can be retrofitted at any position along the conveyor line without interrupting the railing.
- Holder and fixing material included.

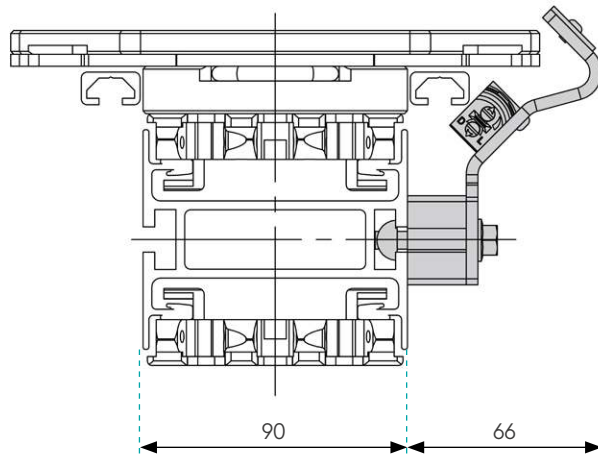
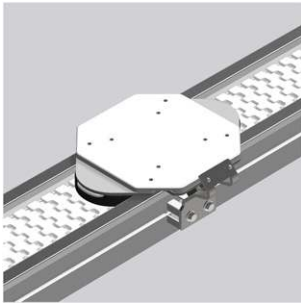

	SENSOR TYPE	PROD.NO.	
FS-CS090SL.WPC position sensor station optical, including fixing material	O6P206 Optical sensor M8 (IFM)	886010-001	1
FS-CS090SL.WPC Inductive position sensor station induction, including fixing material	Ni-EG08K-X-H1341 Inductive Sensor M8 (Turck)	886010-011	1
FS-CS090SL.WPC Position sensor station induction for indexing station, including fixing material	Ni-EG08K-X-H1341 Inductive Sensor M8 (Turck)	886010-012	1
FS-CS090SL.WPC Position sensor bracket M8, without sensor, including fixing material	-	886010-021	1

FS CS090SL.WPC STOPPERS

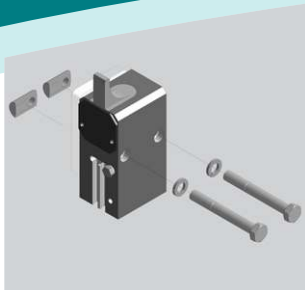

- Stopper for halting and separating workpiece carriers at a specific position.
- Maximum accumulating load of 25 kg per stopper.
 - Attention! - Weight specified relates to:
 - Max. conveying speed of 30 m/min
 - Max. product weight of 10 kg
- Can be retrofitted at any position along the conveyor line without interrupting the railing.

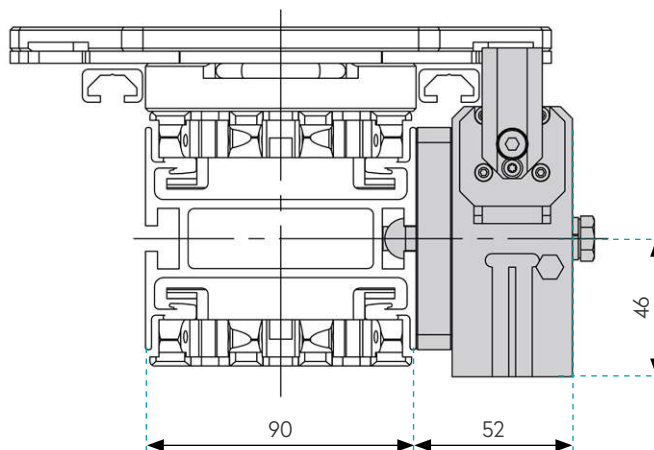
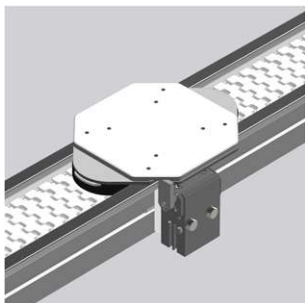
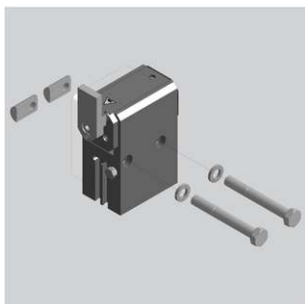

FS CS090SL.WPC STOPPERS

WORKPIECE CARRIER CURVE CONVEYOR SYSTEM

		PROD.NO.	
FS-CS090SL.WPC Stopper without damper, including fixing material	A	886006-001	1
FS-CS090SL.WPC Stopper with damper, including fixing material	B	886006-002	1
FS-CS090SL.WPC Plastic stopper with damper, including fixing material		886006-003	1

FS CS090SL.WPC COMBINATION DRIVE

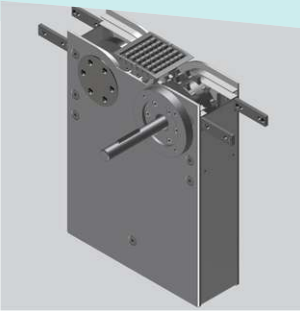

- For driving conveyor lines without chain return, such as closed circuits and spiral conveyors.
- Passive rollerbed transfer.
- With or without motor.

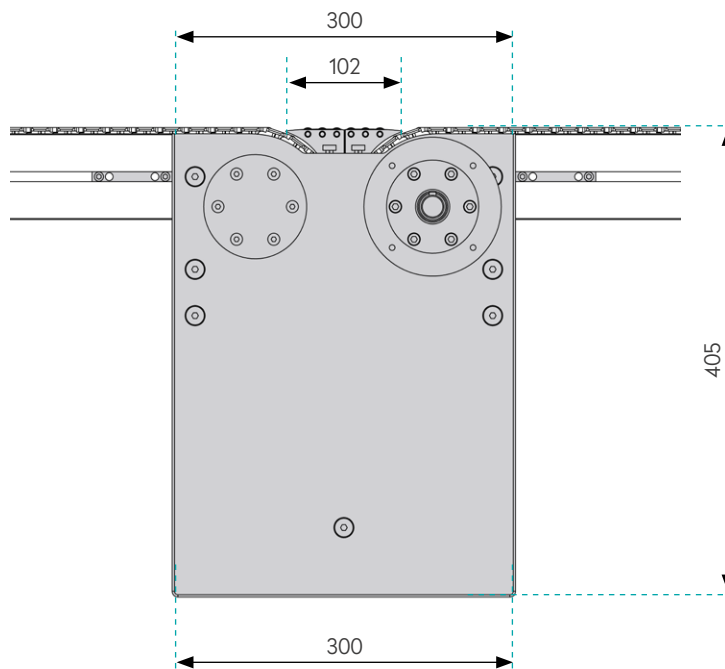

		PROD.NO.		STC (MM)
FS-CS090SL.WPC Combination drive left, including fixing material	A	886011-001	1	118.5
FS-CS090SL.WPC Combination drive right, including fixing material		886011-002	1	118.5

FS CS090SL.WPC COMBINATION DRIVE

WORKPIECE CARRIER CURVE CONVEYOR SYSTEM

FS CS090SL.WPC RAILING PROFILE

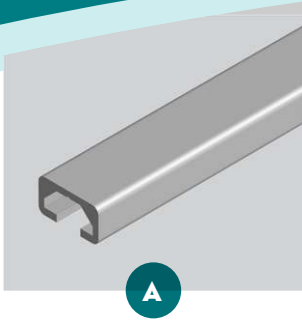



- Railing profile for guiding the workpiece carrier on the conveyor chain.
- Lateral holder for mounting the railing profile to the guide profile.
- Assembly by means of T-slot nuts.

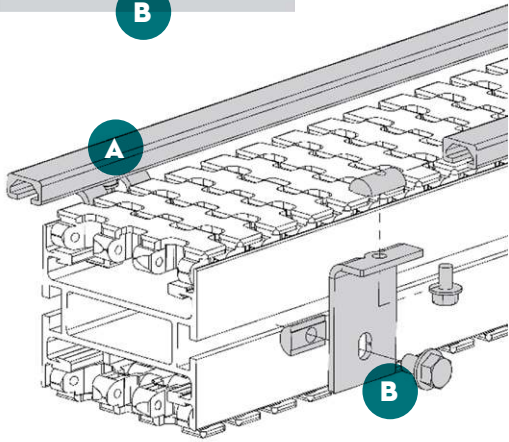
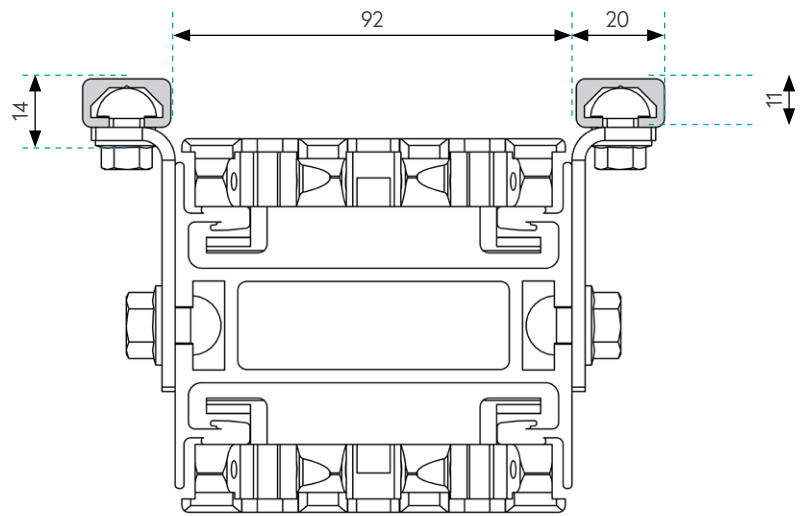

FS CS090SL.WPC RAILING PROFILE



WORKPIECE CARRIER CURVE CONVEYOR SYSTEM

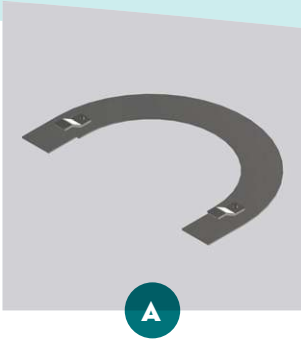

		PROD.NO.			
FS-CS090SL.WPC Railing Aluminium profile	A	886003-001	3m	Aluminium	E6/EV1 anodized finish
FS-CS090SL.WPC Railing bracket, including fixing material	B	886003-002	1	Stainless steel	
8x4 T-slot nut 4xM8 (for connecting Railing profiles), including fixing material		J539634	1	Steel galvanized	

FS CS090SL.WPC DISC CURVE COVER

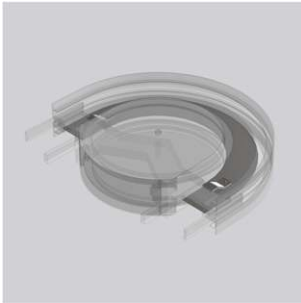

- Shielding for disc curves when using 886011 Combination drive section.
- Fixing material included.



		PROD.NO.		
FS-CS090SL.WPC Disc curve center cover 45°		886005-001	1	Stainless steel
FS-CS090SL.WPC Disc curve center cover 90°		886005-002	1	Stainless steel
FS-CS090SL.WPC Disc curve center cover 135°		886005-003	1	Stainless steel
FS-CS090SL.WPC Disc curve center cover 180°	A	886005-004	1	Stainless steel

FS CS090SL.WPC RAILING DISC CURVE RAILING SET

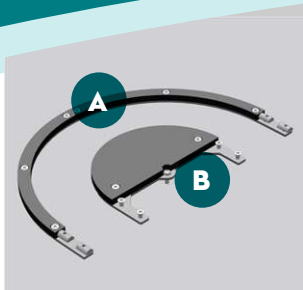

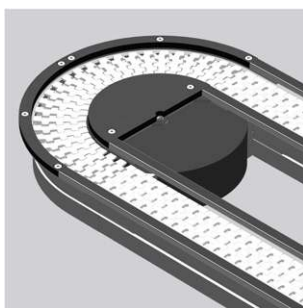

- Railing set for horizontal disc curves
- Fixing material included
- Please order horizontal curve with disc separately.



FS CS090SL.WPC RAILING DISC CURVE RAILING SET

WORKPIECE CARRIER CURVE CONVEYOR SYSTEM

		PROD.NO.		
FS-CS090SL.WPC Railing disc inner curve set 45°		886003-031	1	PA 6 / Nylon black
FS-CS090SL.WPC Railing disc inner curve set 90°		886003-032	1	PA 6 / Nylon black
FS-CS090SL.WPC Railing disc inner curve set 135°		886003-033	1	PA 6 / Nylon black
FS-CS090SL.WPC Railing disc inner curve set 180°	B	886003-034	1	PA 6 / Nylon black
FS-CS090SL.WPC Railing disc outer curve set 45°		886003-041	1	PA 6 / Nylon black
FS-CS090SL.WPC Railing disc outer curve set 90°		886003-042	1	PA 6 / Nylon black
FS-CS090SL.WPC Railing disc outer curve set 135°		886003-043	1	PA 6 / Nylon black
FS-CS090SL.WPC Railing disc outer curve set 180°	A	886003-044	1	PA 6 / Nylon black



FS Solutions BV

Klavermaten 63

7472 DD Goor

T +31 548 515 115

E info@fssolutions.nl

W www.fssolutions.eu

VERSION 2023/10